

Installation Guidelines

Insulator Voltage Sensor—SVMl

15 kV p/n 931X, 25 kV p/n 932X,
& 35 kV p/n 933X

⚠ DANGER

The sensor must be solidly grounded to earth before it is energized. Connection to the phase conductor will energize the sensor and will result in high voltage across the output unless grounded. Failure to ground before energizing can result in serious injury or death.

⚠ DANGER

Sensor must be applied within its electrical and mechanical ratings. Application of sensor in excess of its ratings can result in immediate or delayed electrical or mechanical failure. Failure to apply the sensor within its ratings can result in serious injury or death, or in premature failure of the sensor.

⚠ DANGER

Do not drop. While extremely durable, the sensor is cast from a material that can fracture if dropped onto a hard surface. Fractures can result in either catastrophic failure of the sensor upon energization resulting in serious injury or death, or in premature failure of the sensor.

⚠ CAUTION

Both the sensor cable connectors and the cable connector located on the sensor must remain dry and protected from inclement weather. The connectors are weatherproof once joined, but may allow moisture in the cable when the male or female connectors are left exposed to the elements. Moisture in the cable will result in inaccurate measurement readings.

⚠ CAUTION

Sensor must remain in packaging during transportation to installation site. Transportation of the sensor without its protective packaging may result in chips, cracks, or fractures to the sensor body. Physical damage can result in premature failure of the sensor or reduced electrical ratings.



⚠ WARNING

DO NOT HIPOT. HIPOT (high potential) testing will thermally damage the resistor assemblies in the sensor causing permanent damage. HIPOT testing voids the sensor's warranty. If a HIPOT test is necessary, contact Lindsey for alternate product intended for HIPOT.

Specifications:

Electrical Ratings:

Catalog Number Sequence	931x	932x	933x
Insulation Class	15kV	25kV	35kV
Impulse (BIL)	110kV	150kV	200kV
Leakage Distance (in.)	27.0	27.0	37.25
Dry Arc Distance (in.)	13.6	13.6	17.25
Overall Height (in.)	17.4	17.4	21.5
Corona (extinction)	11kV	19kV	26kV
Voltage Accuracy	0.5% (1% for production prior to 2017)		

Mechanical Ratings:

Cantilever Strength (lbs.)	50	50	50
Weight (lbs.)	10	10	17.2
Shipping Weight (lbs.)	12	12	20

Characteristics:

Lindsey SVMl sensors offer a simple installation procedure. Designed specifically for 15 to 35kV systems, this sensor does not require any special calibration to produce its output at the stated accuracy. The SVMl sensor is intended to be mounted vertically.

Installation

1. Install the mounting bracket to the bottom of the sensor. Do not exceed 20ft-lb (27 Nm) when attaching the bracket to the sensor.

NOTE: The sensor ships with one of two mounting brackets.

- The standard mounting bracket as shown in Figure 1 should be used when making a final onsite installation.
- The heavy-duty mounting bracket as shown in Figure 2 should be used when the sensor is to be installed on equipment frames (e.g., reclosers) before shipment. It is designed to withstand the vibration that occurs during shipment while attached to equipment.

2. De-energize the system then install the sensor to the allocated location.

3. Connect the grounding wire-Thread the grounding wire (#4 copper wire recommended) through the .25" hole of the grounding insert at the bottom then tighten the 3/8-16 bolt.

4. Connect the primary voltage-Thread the jumper wire from the primary conductor through the .25" hole of the high voltage insert on the top then tighten the 3/8-16 bolt.

5. Connect the cable to the customer supplied IED or RTU.

NOTE: When bringing the far end of the cable into a control cabinet, make sure the hole or cable gland in the cabinet can accept the following connector or cable diameters for proper pass through.

Cable End	Min. Hole or Gland Dia.
Pigtail	0.635 in. (16 mm)
Single Sensor Connector	1.46 in. (37 mm)

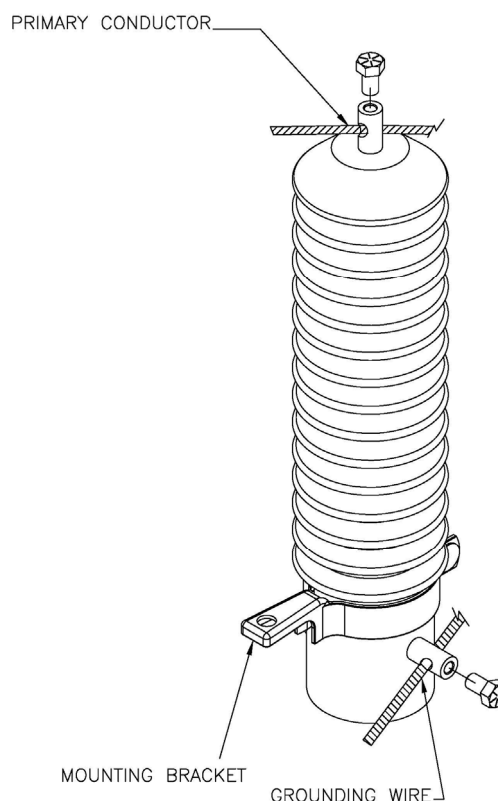

Figure 1: SVMI Sensor (standard mounting bracket shown)

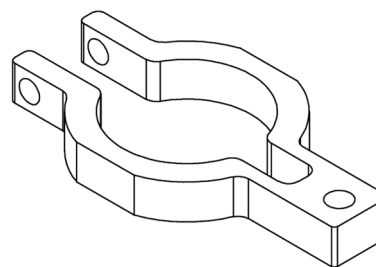

Figure 2: Heavy Duty Mounting Bracket (optional)

SVMI Accessories

Part Number	Description
R-17429	Standard mounting bracket
R-26042	Heavy duty mounting bracket

6. Energize the system.