



Installation Guidelines

Clamp-Top Style Current and Voltage Sensor

15kV P/N 965x/CyzC0, 25kV P/N 966x/CyzC0, & 35kV P/N 967x/CyzC0

⚠ DANGER

The sensor must be solidly grounded to earth before it is energized. Connection to the phase conductor will energize the sensor and will result in high voltage across the output unless grounded. Failure to ground before energizing can result in serious injury or death.

⚠ DANGER

Sensor must be applied within its electrical and mechanical ratings. Application of sensor in excess of its ratings can result in immediate or delayed electrical or mechanical failure. Failure to apply the sensor within its ratings can result in serious injury or death, or in premature failure of the sensor.

⚠ DANGER

Do not drop. While extremely durable, the sensor is cast from a material that can fracture if dropped onto a hard surface. Fractures can result in either catastrophic failure of the sensor upon energization resulting in serious injury or death, or in premature failure of the sensor.

⚠ CAUTION

Sensor must remain in packaging during transportation to installation site. Transportation of the sensor without its protective packaging may result in chips, cracks, or fractures to the sensor body. Physical damage can result in premature failure of the sensor or reduced electrical ratings.

⚠ CAUTION

Both the sensor cable connectors and the cable connector located on the sensor must remain dry and protected from inclement weather. The connectors are weatherproof once joined, but may allow moisture in the cable when the male or female connectors are left exposed to the elements. Moisture in the cable will result in inaccurate measurement readings.

⚠ WARNING

DO NOT HIPOT. HIPOT (high potential) testing will thermally damage the resistor assemblies in the sensor causing permanent damage. HIPOT testing voids the sensor's warranty. If a HIPOT test is necessary, contact Lindsey for alternate product intended for HIPOT.

Specifications:

ELECTRICAL RATINGS			
CATALOG NUMBER SEQUENCE	965x/CyzC0...	966x/CyzC0...	967x/CyzC0...
INSULATION CLASS	15kV	25kV	35kV
IMPULSE (BIL)	110kV	150kV	200kV
LEAKAGE DISTANCE	16.4 in.	24.5 in.	36.5 in.
DRY ARC DISTANCE	8.8 in.	12.6 in.	17.2 in.
OVERALL HEIGHT	23.1 in.	26.6 in.	31.7 in.
WITHSTAND* (60Hz, 1 min.)	34kV	40kV	50kV
CORONA (extinction)	11kV	19kV	26kV

* Current only sensors

MECHANICAL RATINGS			
INSULATION CLASS	15kV	25kV	35kV
CANTILEVER STRENGTH	2,800 lbs.	2,800 lbs.	2,800 lbs.
WEIGHT	42 lbs.	50 lbs.	64 lbs.
SHIPPING WEIGHT	45 lbs.	53 lbs.	67 lbs.

Table 1: Accessories for Clamp-Top Style Sensor

PART #	DESCRIPTION
2004	Horizontal mounting base
2120 W/BOLT	Horizontal Clamp Adapter with mounting bolts
2121 W/BOLT	Vertical Clamp Adapter with mounting bolts
1100T	Trunnion clamp for aluminum conductors 0.25 – 0.80" in diameter
1104T	Trunnion clamp for aluminum conductors 0.60 – 1.06" in diameter
1108T	Trunnion clamp for aluminum conductors 1.00 – 1.50" in diameter
1101T	Trunnion clamp for copper conductors 0.25 – 0.80" in diameter
1105T	Trunnion clamp for copper conductors 0.60 – 1.06" in diameter
2040	3/4" x 2 3/16" mounting stud for metal cross-arms
2041	3/4" x 7" mounting stud for wood cross-arms
R-26525	Arcing bracket (horn) for busbar, clamp-top and substation (tube) style sensors

Characteristics:

The Lindsey Clamp-Top Style Current and Voltage Monitoring Insulator (CVMI) is designed to be installed without de-energizing the line. There is no need to cut the conductor, as a jumper passing through the central tube produces current sensing. Closing the choke on the main conductor shunts approximately 98% of the line current through the jumper. The CVMI can be installed in either a horizontal or vertical line post configuration, depending on the accessory hardware used. See Figures 1 through 3 for installation details. Following the instructions below will insure a safe and simple installation.

Installation:

The Clamp-Top Sensor is designed to be installed without de-energizing or cutting the main utility conductor.

Included with the sensor is an arcing bracket (also known as an arcing horn), P/N R-26525 (see Figure 5) which will be installed under the sensor per Figure 4.

1. Using the sensor catalog number, use the Specifications tables to ensure the sensor is being applied in accordance with its ratings.
2. Pre-assemble the hardware accessories to the insulator. This may include the horizontal or the vertical clamp adapter, the conductor clamp, the bottom-mounting stud and /or the horizontal mounting base. See Table 1. The actual hardware will depend on the specific installation.
3. The bottom half of the choke should be bolted to the conductor clamp. The top half of the choke should be loosely bolted to one side of the bottom half, allowing it to swing out of the when installing the conductor. The choke should not be closed over the main conductor until after the jumper loop has been installed. The top and bottom halves of the choke are marked with a serial number, and it is important that the mating halves of the choke are used. Also, each choke is matched to the CVMI at the time of shipment and should be used with the proper CVMI. The "Certification Data Sheet" for each insulator will indicate the matching choke number to use.
4. If the CVMI is replacing an existing insulator, raise the conductor away from the insulator using approved utility practices and remove the existing insulator.

5. Place the provided arcing bracket (see Figure 5) underneath the sensor and mount both on the crossarm or other mounting surface. The connector socket on the sensor must be aligned with the hole in the arcing bracket. See Figure 4.

Rotate the sensor to place the "H1" identification label on the tube (opposite side of connector) closest towards the feeder source or substation. Mount the sensor and attach using the central mounting stud or bolts using the 4-hole pattern on the bottom of the sensor. See Figure 6.

6. Connect the base of the CVMI to ground.
7. Connect signal cable to the sensor. Hand-tighten to 18-20 ft-lb. Secure with wood staples to crossarm or route inside conduit being careful not to crimp or damage the signal cable. Now, connect cable to controller.

NOTE: When bringing the far end of the cable into a control cabinet, make sure the hole or cable gland in the cabinet can accept the following connector or cable diameters for proper pass through.

Cable End	Min. Hole or Gland Dia.
Pigtail	0.635 in. (16 mm)
Single Sensor Connector	1.46 in. (37 mm)
3-to-1 or 4-to-1 Sensor Connector	2.00 in. (51 mm)

8. Place the bare conductor in the hot line clamp on top of the insulator and secure. Armor rods can be used if desired. If the installation includes a choke, do not close the choke over the main conductor until after the jumper has been installed.
9. Install a four-foot jumper OF EQUAL, OR GREATER AMPACITY AS THE MAIN CONDUCTOR through the embedded, stainless steel tube of the CVMI, using standard techniques. The taps used for the jumper loop should be rated for fully ampacity of the conductor and have a contact resistance of less than 10^{-4} Ohms to insure accurate current measurements. If there is any doubt about the suitability of the taps, two taps can be used. When installing the taps, all of the normal procedures to minimize contact resistance, such as brushing the conductor and applying anti-corrosion grease, should be used.

Installation (continued)

10. If the installation includes a choke, apply a layer of silicone grease to the exposed bottom half of the choke. This grease is supplied in a small packet with the insulator. Swing the top half of the choke into position, align the two halves and bolt into position. Be aware that if the choke is installed on an energized system with sufficient current flowing through the lines, the two halves of the choke will become magnetized and should pull together.

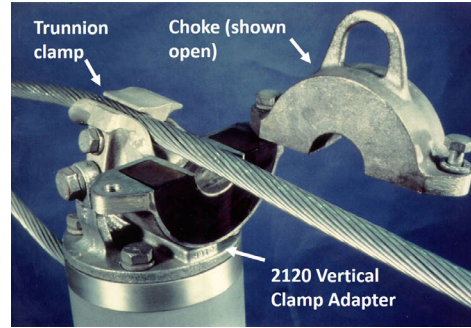

Figure 1: Clamp-top detail
 Note: The conductor fits into the trunnion clamp. The choke is closed only after the jumper wire as shown in Figures 2 and 3 is installed.

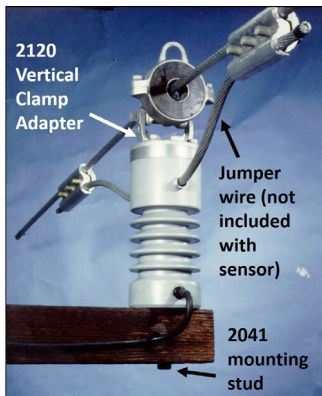

Figure 2: Typical vertical mounting detail

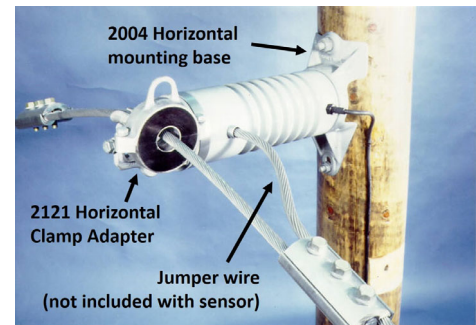

Figure 3: Typical horizontal mounting detail

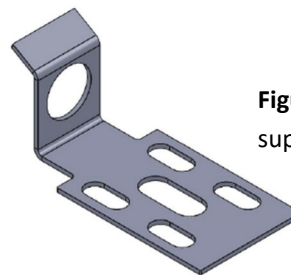

Figure 5: Arcing bracket (arcing horn) supplied with sensor

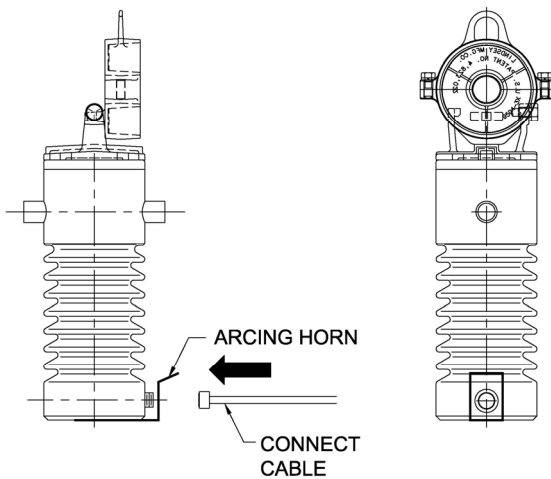

Figure 4: Clamp-top style sensor showing proper orientation of arcing bracket

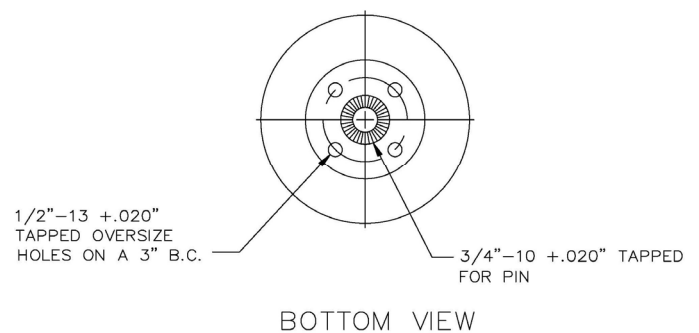

Figure 6: Sensor bottom mounting plate hole pattern