



Suspension Clamps

Suspension Clamps, Series 1300 (For ACSR and all aluminum conductors)

Lindsey's 1300 Series Aluminum Suspension Clamps are recommended for ACSR or aluminum conductors. The clamps bodies and keepers are manufactured from light weight, high strength A 356-T6 aluminum alloy. U-bolts, nuts, lockwashers and clevis pins are hot dip galvanized steel. Humpback cutter keys are stainless steel.

Clamps may be ordered with factory assembled clevis eyes or socket eyes fittings by adding a "C" or "S" respectively to the catalog number (i.e., 1332C or 1332S). These fittings are hot clip galvanized ductile iron. Socket fittings are for use with ANSI Class 52-3 or 52-5 balls.

To replace the clamps clevis pin with a bolt, nut and cutter key, add "BNC" to the catalog number (i.e., 1332BNC). The recommended torque on the U-bolts is 480 inch-pounds for 1/2" and 720 inch-pounds for 5/8"

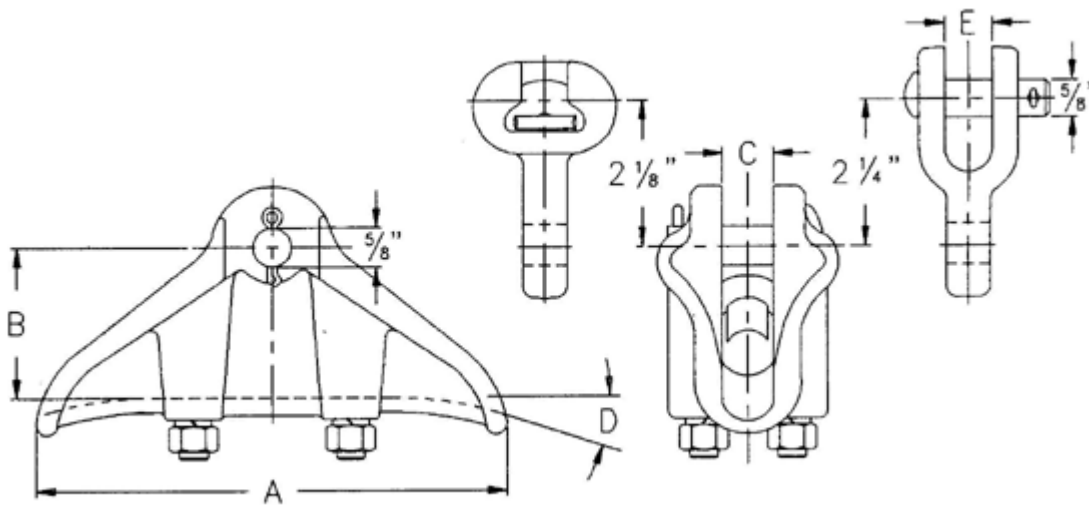

CATALOG NUMBER	CONDUCTOR Range (Inches)	Clamp Dimensions (Inches)					U-Bolts Inches	Ultimate strength
		A	B	C	D	E		
1328	0.20-0.62	6 1/2	2 1/8	3/4	30	11/16	1/2	17,000
1330	0.25-0.75	6 1/2	2 1/4	7/8	30	11/16	1/2	18,000
1332	0.40-0.86	7 1/2	2 3/8	1	30	11/16	1/2	18,000
1334	0.40-1.05	7 1/2	2 1/2	1 1/8	30	11/16	1/2	25,000
1336	0.75-1.19	8	2 5/8	1 3/8	30	13/16	1/2	25,000
1340	0.80-1.39	8	2 7/8	1 1/2	22 1/2	13/16	1/2	25,000
1342	0.90-1.49	9	3 1/8	1 5/8	22 1/2	13/16	1/2	25,000
1344	1.00-1.62	9 1/2	3 1/4	1 7/8	22 1/2	13/16	1/2	25,000
1346	1.00-1.82	10 1/8	3 3/8	2	22 1/2	13/16	1/2	25,000
1348	1.40-2.04	10 1/4	3 1/2	2 1/4	20	13/16	1/2	25,000
1350	1.62-2.27	11	4	2 3/8	20	13/16	5/8	25,000