

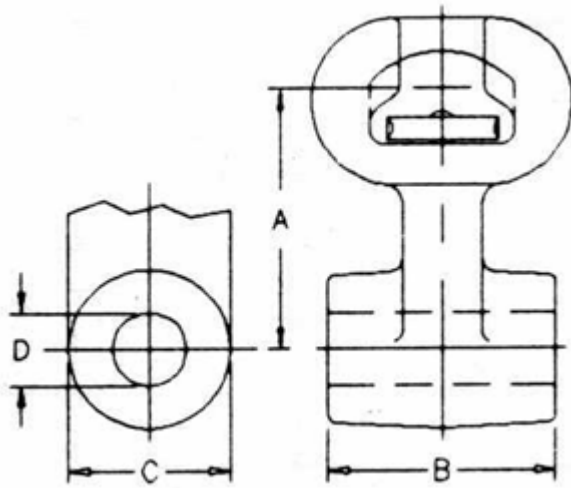

T&D Fittings/ Socket Fittings

Socket Eyes



CATALOG NUMBER	ANSI CLASS	FIGURE NUMBER	DIMENSIONS (INCHES)				ULTIMATE STRENGTH (LBS)	WEIGHT PER 100 PCS. (LBS)
			A	B	C	D		
3315	52 - 3,52 - 5	1	2 5/16	1/2	1 3/4	11/16	20,000	134
3317	52 - 3,52 - 5	1	2 5/16	5/8	1 3/4	11/16	25,000	144
3390	52 - 3,52 - 5	2	2 3/16	1 1/2	1 7/16	13/16	30,000	161
3349	52 - 3,52 - 5	2	2 5/16	1/2	1 1/2	11/16	15,000	130
3350	52 - 3,52 - 5	2	2 5/16	3/4	1 1/2	11/16	30,000	133
3351	52 - 3,52 - 5	2	2 5/16	7/8	1 1/2	11/16	30,000	139
3353	52 - 3,52 - 5	2	2 5/16	1	1 1/2	11/16	30,000	145
3355	52 - 3,52 - 5	2	2 5/16	1 1/16	1 3/4	13/16	30,000	153
3354	52 - 3,52 - 5	2	2 5/16	1 1/8	1 1/2	11/16	30,000	151
3327	52 - 3,52 - 5	2	2 5/16	1 1/8	1 1/2	13/16	30,000	151
3356	52 - 3,52 - 5	2	2 5/16	1 1/4	1 1/2	11/16	30,000	157
3357	52 - 3,52 - 5	2	2 5/16	1 3/8	1 1/2	11/16	30,000	163
3359	52 - 3,52 - 5	2	2 5/16	1 1/2	1 1/2	11/16	30,000	169
3360	52 - 3,52 - 5	2	2 5/16	1 1/2	1 1/2	13/16	30,000	169
3361	52 - 3,52 - 5	2	2 5/16	1 3/4	1 1/2	11/16	30,000	181
3362	52 - 3,52 - 5	2	2 5/16	1 3/4	1 11/16	13/16	30,000	206
3363	52 - 3,52 - 5	2	2 5/16	1 7/8	1 1/2	11/16	30,000	187
3364	52 - 3,52 - 5	2	2 5/16	1 7/8	1 1/2	13/16	30,000	187
3365	52 - 3,52 - 5	2	2 5/16	2	1 1/2	11/16	30,000	195
3367	52 - 3,52 - 5	2	2 5/16	2	1 1/2	13/16	30,000	195
3378	52 - 3,52 - 5	2	2 11/16	3/4	2	13/16	30,000	204
3370	52 - 3,52 - 5	2	3	2 1/16	1 3/4	13/16	30,000	247
3371	52 - 3,52 - 5	2	3	2 3/16	1 3/4	13/16	30,000	255
3374	52 - 3,52 - 5	2	3	2 7/16	1 3/4	13/16	30,000	271
3376	52 - 3,52 - 5	2	3	2 11/16	1 3/4	13/16	30,000	287
3377	52 - 3,52 - 5	2	3	2 7/8	1 3/4	13/16	30,000	299
3379*	52 - 3,52 - 5	2	3	1 to 2 7/8*	1 3/4	13/16 to 15/16*	30,000	183 - 335
3388	52 - 3,52 - 5	2	3	1 1/4	2	1 1/16	30,000	170
3386	52 - 8,52 - 11	2	3 1/4	1 3/4	1 3/4	13/16	50,000	317
3385	52 - 8,52 - 11	2	5 5/16	1 1/2	2	13/16	50,000	523
3387	52 - 8,52 - 11	2	5 5/16	1 7/8	2	13/16	50,000	562
3389*	52 - 8,52 - 11	2	5 5/16	7/8 to 2 1/4*	2	13/16 to 15/16*	50,000	470 - 520

* Specify desired "B" and "D" dimensions.

Socket Clevises

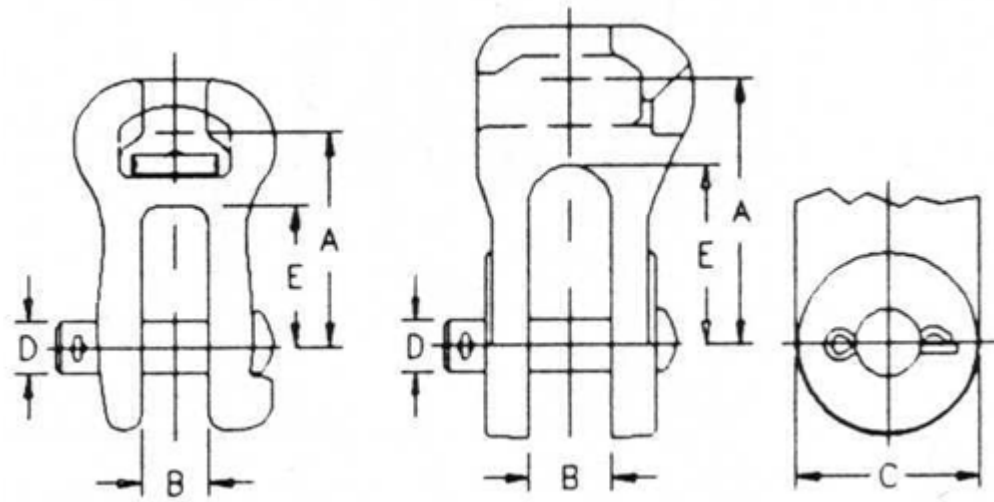

(with anti-rotation hump)

CATALOG NUMBER	ANSI CLASS	FIGURE NUMBER	DIMENSIONS (INCHES)					ULTIMATE STRENGTH (LBS)	WEIGHT PER 100 PCS. (LBS)
			A	B	C	D	E		
3179*	52 - 3,52 - 5	2	2 1/4	15/16	2	5/8	1 5/16	20,000	270
3187	52 - 3,52 - 5	1	2 5/8	13/16	2	5/8	1 3/4	25,000	270
3183*	52 - 3,52 - 5	1	2 5/8	7/8	2	5/8	1 5/8	30,000	270
3185*	52 - 3,52 - 5	2	2 5/8	7/8	2	5/8	1 5/8	15,000	270
3182	52 - 3,52 - 5	1	4 1/2	13/16	2	5/8	2	30,000	320
3180	52 - 3,52 - 5	1	4 1/2	15/16	1 3/4	5/8	2	30,000	320
3181	52 - 8,52 - 11	1	4 1/4	15/16	2 1/4	3/4	3 1/4	50,000	520

*With anti-rotation hump for clevis pin.

Socket Y-Clevises

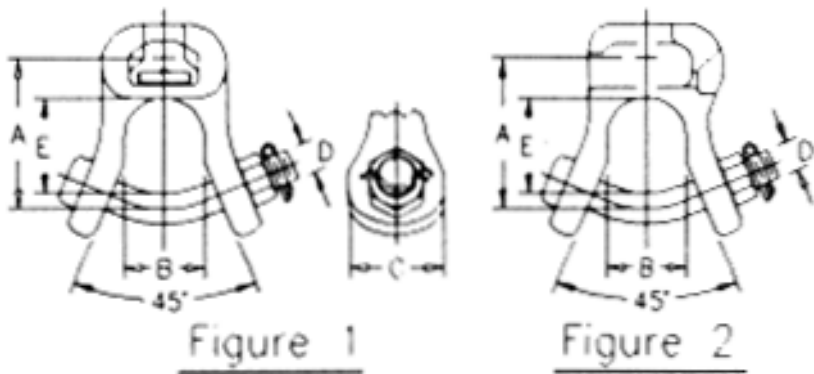

CATALOG NUMBER	ANSI CLASS	FIGURE NUMBER	DIMENSIONS (INCHES)					ULTIMATE STRENGTH (LBS)	WEIGHT PER 100 PCS. (LBS)
			A	B	C	D	E		
3340	52 - 3,52 - 5	1	2 5/8	1 1/2	2	3/4	1 3/8	30,000	281
3341	52 - 3,52 - 5	2	2 5/8	1 1/2	2	3/4	1 1/2	30,000	281



3343	52 - 8,52 - 11	1	3 1/16	1 1/2	2 1/2	7/8	1 1/2	50,000	410
3344	52 - 8,52 - 11	1	3 1/8	1 1/2	2 5/16	7/8	1 5/8	50,000	660
3345	52 - 8,52 - 11	2	3 1/4	1 1/2	2 5/16	7/8	1 3/4	50,000	660